**User's
Manual**

**WX1
GateOPC**

vigilantplant.®

Foreword

This manual describes the functions and operating procedures of GateOPC. To ensure correct use, please read this manual thoroughly before beginning operation. After reading the manual, keep it in a convenient location for quick reference in the event a question arises.

GateOPC is a software program that uses the OPC (OLE for process control) protocol to acquire measurement data and pass that data to DAQLOGGER or Remote Monitor.

Note

- The contents of this manual are subject to change without prior notice as a result of improvements in the software's performance and functions.
- Every effort has been made in the preparation of this manual to ensure the accuracy of its contents. However, should you have any questions or find any errors, please contact your nearest YOKOGAWA representative as listed on the back cover of this manual.
- Copying or reproducing all or any part of the contents of this manual without the permission of Yokogawa Electric Corporation is strictly prohibited.
- Use of this product (software and this manual) on more than one computer at the same time is prohibited. Use by more than one user is also prohibited.
- Transfer or lending of this product to any third party is prohibited.
- Yokogawa Electric Corporation provides no guarantees other than for physical deficiencies found on the original disk or this manual upon opening the product package.
- **License numbers will not be reissued. Please keep the license number in a safe place.**

Copyrights

- Copyrights for the programs included on the CD-ROM are attributable to Yokogawa Electric Corporation.

Trademarks

- DAQWORX, DAQLOGGER, and DAQEXPLORER are registered trademarks or trademarks of Yokogawa Electric Corporation.
- Microsoft and Windows are registered trademarks or trademarks of Microsoft Corporation in the United States and/or other countries.
- Adobe and Acrobat are registered trademarks or trademarks of Adobe Systems Incorporated.
- Company and product names that appear in this manual are registered trademarks or trademarks of their respective holders.
- The company and product names used in this manual are not accompanied by the registered trademark or trademark symbols (® and ™).

Revisions

- 1st Edition June 2003
- 2nd Edition February 2003
- 3rd Edition June 2007
- 4th Edition March 2008
- 5th Edition January 2009

Terms and Conditions of the Software License

NOTICE - PLEASE READ CAREFULLY BEFORE USE

Thank you very much for purchasing this medium containing a software program and related documentation provided by Yokogawa Electric Corporation (hereinafter called "Yokogawa"), and the program contained, embedded, inserted or used in the medium (hereinafter called the "Yokogawa Software Program").

By installing the Yokogawa Software Program, you acknowledge that you understand and fully agree to the "Terms and Conditions of the Software License" (hereinafter called "Terms and Conditions") which is written in the documentation and separately attached. Accordingly, the Terms and Conditions bind you.

The Yokogawa Software Program and its related documentation including ownership of copyright shall remain the exclusive property of Yokogawa or those third parties who grants Yokogawa the rights.

Yokogawa hereby grants you permission to use the Yokogawa Software Program on the conditions that you agree to the Terms and Conditions before you install it in or onto a computer.

IF YOU DO NOT AGREE TO THE TERMS AND CONDITIONS, YOU CANNOT INSTALL THIS MEDIUM, AND MUST PROMPTLY RETURN IT TO YOKOGAWA OR ITS DESIGNATED PARTY.

Terms and Conditions of the Software License

Yokogawa Electric Corporation, a Japanese corporation (hereinafter called "Yokogawa"), grants permission to use this Yokogawa Software Program (hereinafter called the "Licensed Software") to you on the conditions that you agrees to the terms and conditions stipulated in Article 1 hereof.

You, as the Licensee (hereinafter called "Licensee"), shall agree to the following terms and conditions on the software license (hereinafter called the "Agreement") when the Licensed Software is installed by the Licensee.

Please note that Yokogawa grants the Licensee permission to use the Licensed Software under the terms and conditions herein and in no event shall Yokogawa intend to sell or transfer the Licensed Software to the Licensee.

Article 1 (Licensed Software under these Terms and Conditions)

1.1 The terms and conditions stipulated herein shall bind any Licensee who purchases the Licensed Software on the condition that the Licensee consents to agree to the terms and conditions stipulated herein.

1.2 The "Licensed Software" and required number of license herein shall be specified in the following paragraphs (1) and (2) respectively. The Licensed Software means and includes all applicable programs and documentation, without limitation, all proprietary technology, algorithms, a factor, invariant, process and/or other know-how contained therein. These terms and conditions shall also govern any additional software to the Licensed Software inclusive of its version-up or revision-up if Yokogawa provides them to the Licensee.

(1) Licensed Software Name: Data Acquisition Software Suite DAQWORX

(2) Number of License: Same number as those media for the Licensed Software shall be acquired for installation.

Article 2 (Grant of License)

2.1 Yokogawa grants the Licensee, for the purpose of single use, non-exclusive and non-transferable license of the Licensed Software with the license fee separately agreed upon by both parties.

2.2 The Licensee is, unless otherwise agreed upon in writing by Yokogawa, not entitled to change, sell, distribute, transfer, or sublicense the Licensed Software.

2.3 The Licensed Software shall not be copied in part or in whole except for keeping one (1) copy for back-up purpose. The Licensee shall secure or supervise the copy of the Licensed Software by the Licensee itself with great, strict, and due care.

2.4 The Licensed Software remains the exclusive property of Yokogawa and, if any, those of third parties from whom Yokogawa is sublicensed (hereinafter such third party's software is called "Third Party Software", which may include any software program made or coded by affiliates of Yokogawa). In no event shall the Licensee dump, reverse assemble, reverse compile, or reverse engineer the Licensed Software so that the Licensee may translate the Licensed Software into other programs or change it into a man-readable form from the source code of the Licensed Software. Unless otherwise separately agreed upon by Yokogawa, Yokogawa shall not provide the Licensee the source code for the Licensed Software.

2.5 The Licensed Software and its related documentation inclusive of its ownership of copyright shall be the proprietary property of Yokogawa or a third party who grants Yokogawa the rights. In no event shall the Licensee transfer, lease, sublicense, or assign any rights relating to the Licensed Software.

2.6 Yokogawa may use or add copy protection in or onto the Licensed Software. In no event shall, regardless of the purpose, the Licensee remove or attempt to remove such copy protection.

2.7 The Licensed Software may include the Third Party Software. In the case that Yokogawa is granted permission to sublicense to third parties by any licensors (sub-licensor) of the Third Party Software under different terms and conditions than those stipulated in this Agreement, the Licensee shall observe such terms and conditions of which Yokogawa notifies the Licensee in writing separately.

2.8 In no event shall the Licensee modify, remove or delete a copyright notice of Yokogawa and its licensor contained in the Licensed Software, including any copy thereof.

Article 3 (Restriction of Specific Use)

3.1 The Licensed Software shall not be intended specifically to be designed, developed, constructed, manufactured, distributed or maintained for the purpose of the following events:

- a) Operation of any aviation, vessel, or support of those operations from the ground;
- b) Operation of nuclear products, its facilities and/or radiation apparatus;
- c) Operation of nuclear weapons, chemical weapons and/or biological weapons, or railroad; or
- d) Operation of medical instrumentation directly utilized for humankind or the human body.

3.2 Even if the Licensee uses the Licensed Software for the purposes in the preceding Paragraph 3.1, Yokogawa has no liability to or responsibility for any claims or damages arising out of the use or operations of the Licensed Software, and the Licensee agrees, on its own responsibility, to solve and settle the claims and damages and to defend, indemnify or hold Yokogawa totally harmless, from or against any liabilities, losses, damages and expenses (including fees for recalling the Products and reasonable attorney's fees and court costs), or claims arising out of and related to the above-said claims and damages.

Article 4 (Warranty)

4.1 The Licensee shall agree that the Licensed Software shall be provided to the Licensee on an "as is" basis when delivered. If defect(s), such as damage to the medium of the Licensed Software, attributable to Yokogawa is found, Yokogawa agrees to replace, free of charge, any Licensed Software on condition that the defective Licensed Software shall be returned to Yokogawa's specified authorized service facility within 12 month from the delivery of Yokogawa after opening the Package at the Licensee's expense. As the Licensed Software is provided to the Licensee on an "as is" basis when delivered, in no event shall Yokogawa warrant that any information on or in the Licensed Software, including without limitation, data on computer programs and program listings, be completely accurate, correct, reliable, or the most updated.

4.2 Notwithstanding the preceding Paragraph 4.1, when Third Party Software is included in the Licensed Software, the warranty period and related conditions that apply shall be those established by the provider of the third party software.

- 4.3 When Yokogawa decides in its own judgement that it is necessary, Yokogawa may from time to time provide the Licensee with Release Upgrades specified by Yokogawa (hereinafter called "Release Upgrades").
- 4.4 Notwithstanding the preceding Paragraph 4.3, in no event shall Yokogawa provide Updates where the Licensee or any third party conducted renovation or improvement of the Licensed Software.
- 4.5 Correction of nonconformity in the manner and for the period of time provided above shall be the Licensee's sole and exclusive remedy for any failure of Yokogawa to comply with its obligations and shall constitute fulfillment of all liabilities of Yokogawa and any third party licensing the Third Party Software to Yokogawa (including any liability for direct, indirect, special, incidental or consequential damages) whether in warranty, contract, tort (including negligence but excluding willful conduct or gross negligence by Yokogawa) or otherwise with respect to or arising out of the use of the Licensed Software.
- 4.6 THE FOREGOING WARRANTIES ARE EXCLUSIVE AND IN LIEU OF ALL OTHER WARRANTIES OF QUALITY AND PERFORMANCE, WRITTEN, ORAL, OR IMPLIED, AND ALL OTHER WARRANTIES INCLUDING ANY IMPLIED WARRANTIES OF MERCHANTABILITY OR FITNESS FOR A PARTICULAR PURPOSE ARE HEREBY DISCLAIMED BY YOKOGAWA AND ALL THIRD PARTIES LICENSING THIRD PARTY SOFTWARE TO YOKOGAWA.

Article 5 (Infringement)

- 5.1 If and when any third party should demand injunction, initiate a law suit, or demand compensation for damages against the Licensee under patent right (including utility model right, design patent, and trade mark), copyright, and any other rights relating to any of the Licensed Software, the Licensee shall promptly notify Yokogawa in writing to that effect.
- 5.2 In the case of the preceding Paragraph 5.1, the Licensee shall assign to Yokogawa all of the rights to defend the Licensee and to negotiate with the claiming party. Furthermore, the Licensee shall provide Yokogawa with necessary information or any other assistance for Yokogawa's defense and negotiation. If and when such a claim should be attributable to Yokogawa, subject to the written notice to Yokogawa stated in the preceding Paragraph 5.1, Yokogawa shall defend the Licensee and negotiate with the claiming party at Yokogawa's cost and expense and be responsible for the final settlement or judgment granted to the claiming party in the preceding Paragraph 5.1.
- 5.3 When any assertion or allegation of the infringement of the third party's rights defined in Paragraph 5.1 is made, or when at Yokogawa's judgment there is possibility of such assertion or allegation, Yokogawa will, at its own discretion, take any of the following countermeasures at Yokogawa's cost and expense.
- To acquire the necessary right from a third party which has lawful ownership of the right so that the Licensee will be able to continue to use the Licensed Software;
 - To replace the Licensed Software with an alternative one which avoids the infringement; or
 - To remodel the Licensed Software so that the Licensed Software can avoid the infringement of such third party's right.
- 5.4 If and when Yokogawa fails to take either of the countermeasures as set forth in the preceding subparagraphs of Paragraph 5.3, Yokogawa shall indemnify the Licensee only by paying back the price amount of the Licensed Software which Yokogawa has received from the Licensee.
- THE FOREGOING PARAGRAPHS STATE THE ENTIRE LIABILITY OF YOKOGAWA AND ANY THIRD PARTY LICENSING THIRD PARTY SOFTWARE TO YOKOGAWA WITH RESPECT TO INFRINGEMENT OF THE INTELLECTUAL PROPERTY RIGHTS INCLUDING BUT NOT LIMITED TO, PATENT AND COPYRIGHT.

Article 6 (Liabilities)

- 6.1 If and when the Licensee should incur any damage relating to or arising out of the Licensed Software or service that Yokogawa has provided to the Licensee under the conditions herein due to a reason attributable to Yokogawa, Yokogawa shall take actions in accordance with this Agreement. However, in no event shall Yokogawa be liable or responsible for any special, incidental, consequential and/or indirect damage, whether in contract, warranty, tort, negligence, strict liability, or otherwise, including, without limitation, loss of operational profit or revenue, loss of use of the Licensed Software, or any associated products or equipment, cost of capital, loss or cost of interruption of the Licensee's business, substitute equipment, facilities or services, downtime costs, delays, and loss of business information, or claims of customers of Licensee or other third parties for such or other damages. Even if Yokogawa is liable or responsible for the damages attributable to Yokogawa and to the extent of this Article 6, Yokogawa's liability for the Licensee's damage shall not exceed the price amount of the Licensed Software or service fee which Yokogawa has received. The Licensee agrees that Yokogawa shall be released or discharged from part or all of the liability under this Agreement if the Licensee modifies, remodels, combines with other software or products, or causes any deviation from the basic specifications or functional specifications, without Yokogawa's prior written consent.
- 6.2 All causes of action against Yokogawa arising out of or relating to this Agreement or the performance or breach hereof shall expire unless Yokogawa is notified of the claim within one (1) year of its occurrence.
- 6.3 In no event, regardless of cause, shall Yokogawa assume responsibility for or be liable for penalties or penalty clauses in any contracts between the Licensee and its customers.

Article 7 (Limit of Export)

Unless otherwise agreed by Yokogawa, the Licensee shall not directly or indirectly export or transfer the Licensed Software to any countries other than those where Yokogawa permits export in advance.

Article 8 (Term)

This Agreement shall become effective on the date when the Licensee receives the Licensed Software and continues in effect unless or until terminated as provided herein, or the Licensee ceases using the Licensed Software by itself or with Yokogawa's thirty (30) days prior written notice to the Licensee. When aforesaid termination or cease is occurred, the Licensee shall immediately destroy and/or eliminate the Licensed Software and related documents without retaining any copies or extracts thereof. However, upon specifically instructed by Yokogawa, they shall be returned to Yokogawa or its designated third party.

Article 9 (Injunction for Use)

During the term of this Agreement, Yokogawa may, at its own discretion, demand injunction against the Licensee in case that Yokogawa deems that the Licensed Software is used improperly or under severer environments other than those where Yokogawa has first approved, or any other condition which Yokogawa may not permit.

Article 10 (Termination)

Yokogawa, at its sole discretion, may terminate this Agreement without any notice or reminder to the Licensee if the Licensee violates or fails to perform this Agreement. However, Articles 5, 6, and 11 shall survive even after the termination.

Article 11 (Jurisdiction)

Any dispute, controversies, or differences between the parties hereto as to interpretation or execution of this Agreement shall be resolved amicably through negotiation between the parties upon the basis of mutual trust. Should the parties fail to agree within ninety (90) days after notice from one of the parties to the other, both parties hereby irrevocably submit to the exclusive jurisdiction of the Tokyo District Court (main office) in Japan for settlement of the dispute to the fullest extent allowed by applicable law.

Article 12 (Governing Law)

This Agreement shall be governed by and construed in accordance with the laws of Japan. The Licensee expressly agrees to waive absolutely and irrevocably and to the fullest extent permissible under applicable law any rights against the laws of Japan which may have pursuant to the Licensee's local law.

Article 13 (Severability)

In the event that any provision hereof is declared or found to be illegal by any court or tribunal of competent jurisdiction, such provision shall be null and void with respect to the jurisdiction of that court or tribunal and all the remaining provisions hereof shall remain in full force and effect.

Overview of This Manual

Structure of This Manual

This user's manual consists of the following chapters.

Chapter	Title	Description
1	Overview	Gives an overview of the GateOPC software. Lists the PC requirements for running GateOPC and gives information about system configuration.
2	Operating Procedure	Lists procedures for entering environment and data acquisition interval settings, running the program, and viewing the status display.
3	Detailed Description of Functions	Provides a detailed description of the functions of GateOPC. Lists error messages, their causes, and their corrective actions.
Index		An alphabetical index of the manual's contents.

Scope of This Manual

This manual provides instructions on how perform basic operations with the software when running under Windows XP, Windows 2000, and Windows Vista. For information regarding the basic operations of Windows, see the Windows user's manual.

Conventions Used in This Manual

- **Units**

K Denotes 1024. Example: 10 KB

M Denotes 1024K. Example: 10 MB

G Denotes 1024M. Example: 2 GB

- **Boldface Type**

Hardware and software controls that the user manipulates such as dialog boxes, buttons, and menu commands are often set in boldface type.

- **Subheadings**

On pages in chapters 1 through 3 that describe operating procedures, the following subheadings are used to distinguish the procedure from their explanations.

Procedure

This subsection contains the operating procedure used to carry out the function described in the current section. All procedures are written with inexperienced users in mind; experienced users may not need to carry out all the steps.

Note

Calls attention to information that is important for proper operation of the instrument.

Contents

Foreword.....	i
Terms and Conditions of the Software License.....	ii
Overview of This Manual	iv
Chapter 1 Overview	
1.1 Overview of GateOPC Functions.....	1-1
1.2 System Overview.....	1-2
Chapter 2 Operating Procedure	
2.1 Running and Exiting GateOPC	2-1
2.2 Entering Environment Settings	2-2
2.3 Loading Data from the OPC Server and Transferring It to DAQLOGGER or Remote Monitor	2-12
2.4 Viewing the Status of the Executable Function	2-14
2.5 Viewing Version Information	2-15
Chapter 3 Detailed Description of Functions	
3.1 Overview	3-1
Environment Setting Functions.....	3-1
Executable Function	3-2
Status Display Function	3-2
3.2 Detailed Description of Functions	3-3
OPC Server	3-3
Interfaces Used.....	3-3
Name of Remote PC.....	3-4
Selecting/Setting the ProgID.....	3-4
Simultaneous Connections of Up to 16 OPC Servers	3-4
Interval at Which Data Is Acquired from the OPC Servers	3-4
Browsing OPC Server Items.....	3-5
Creating Groups/Group Names	3-5
Group Data Update Interval.....	3-5
Group Percent Deadband.....	3-5
Adding Items to Groups	3-6
Setting Item Properties	3-6
Acquiring Data at Fixed Intervals.....	3-7
Time of GateOPC internal data.....	3-7
Test Acquisition	3-7
Communication Retry	3-7
Scan Mode.....	3-8
Monitor Server Function	3-8
Executable Function Status Display	3-8
3.3 Message and Corrective Actions	3-9
Error.....	3-9
Warning.....	3-9
Message	3-9
Executable Function Messages.....	3-10

Index

1.1 Overview of GateOPC Functions

GateOPC is a software program that uses the OPC (OLE for process control) protocol—Microsoft's data exchange technology that is supported in a wide range of industries—to acquire measurement data and pass that data to Yokogawa's DAQLOGGER or Remote Monitor. Using GateOPC allows you to acquire and monitor data on DAQLOGGER or Remote Monitor that comes from Yokogawa recorders or other companies' DCS and PLC devices with OPC server functionality.

Yokogawa's DAQLOGGER is a software program that allows users to open a connection from their PC to various kinds of Yokogawa recorders (the μ R, VR, DARWIN, DX, MV, and CX) and perform data logging and monitoring.

Yokogawa's Remote Monitor is application software that enables monitoring of data logged by recorders or data logging software.

Features

- Acts as an OPC client, connecting to an OPC DA (data access) server (hereinafter OPC server).
- Can acquire data from 16 OPC servers simultaneously.
- Measurement can be performed at intervals of up to 0.5 seconds.
 - * However, DAQLOGGER's shortest interval is 1 second. Also, the maximum speed of 0.5 seconds may not be attainable depending on the amount of data being read, the response time of the device, and the communication speed.

1.2 System Overview

System

This software can acquire data from OPC DA revision 2.0 servers or later.

Required Operating Systems

Run DAQWORX under any of the following operating systems.

- Windows 2000 Professional SP4
- Windows XP Home Edition SP2, SP3
- Windows XP Professional SP2, SP3 (excluding Windows XP Professional x64 Edition)
- Windows Vista Home Premium, SP1 (excluding the 64-bit edition)
- Windows Vista Business, SP1 (excluding the 64-bit edition)

The language displayed by the software under different language versions of the OS are as follows.

OS Language	Software Language
Japanese	Japanese
Other	English

Hardware Requirements

The following hardware and software are required to use GateOPC.

- PC: A PC that runs one of the OS above, and that meets the following CPU and memory requirements.
When Using Windows 2000 or Windows XP
Pentium 4, 1.6 GHz or faster
512 MB or more of memory
When Using Windows Vista
Pentium 4, 3 GHz or faster
2GB or more of memory
- Free disk space: 200 MB or more
- Communication device: An Ethernet (when connecting to DAQLOGGER or Remote Monitor) port that is recognized by the operating system.
- CD-ROM drive: Used to install the software
- Peripheral devices: A mouse supported by the operating system
- GP-IB port: Required for GPIB communications between the software and a WT series instrument
- Monitor: **When Using Windows 2000 or Windows XP**
A monitor supported by the OS of 1024 × 768 dot or higher and 65,536 colors or more.
When Using Windows Vista
A video card recommended for use with Vista and a monitor supported by the OS of 1024 × 768 dot or higher and 65,536 colors or more.

System Configuration

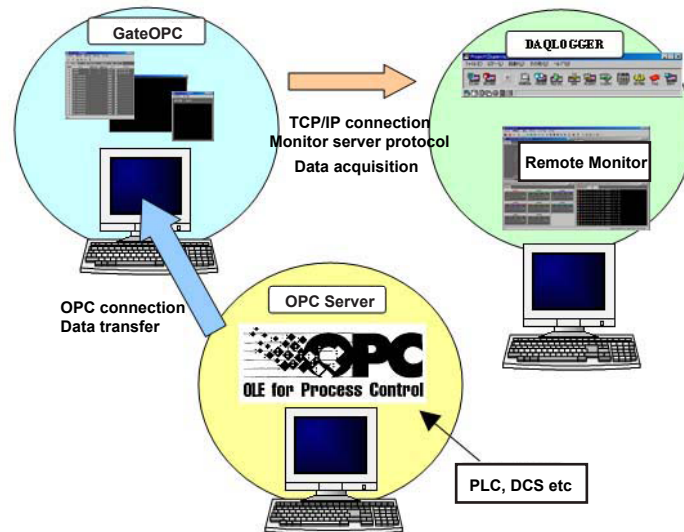

It is recommended that you run GateOPC and DAQLOGGER or Remote Monitor on separate PCs depending on the number of devices that the system supports and other factors affecting the load.

Software Configuration

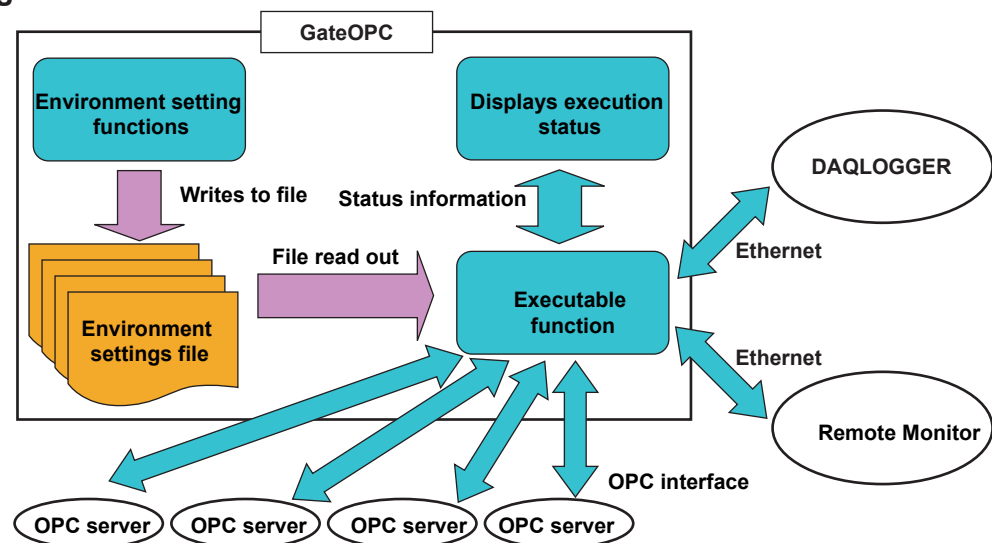

GateOPC Configurator consists of three separate software functions. The role of each function within the configurator is as follows:

- Environment Setting Functions**
 These functions allow the user to enter various settings required by the executable function for communications with OPC servers, as well as those required for data transfers to and from DAQLOGGER and Remote Monitor. The user can also use the environment setting functions to start/stop the executable function, or view the execution status.
- Executable Function**
 The function reads data from OPC servers at fixed intervals. Up to 16 OPC servers can be linked. It also acts as a monitor server, transferring data to DAQLOGGER and Remote Monitor.
- Status Display Function**
 The execution status of the executable software can be displayed, as well as the connection status of DAQLOGGER and Remote Monitor.

2.1 Running and Exiting GateOPC

Running the Software Procedure

1. From the Windows Start menu, choose **Programs > YOKOGAWA DAQWORX > GateOPC > GateOPC**.

The GateOPC Configurator dialog box opens.

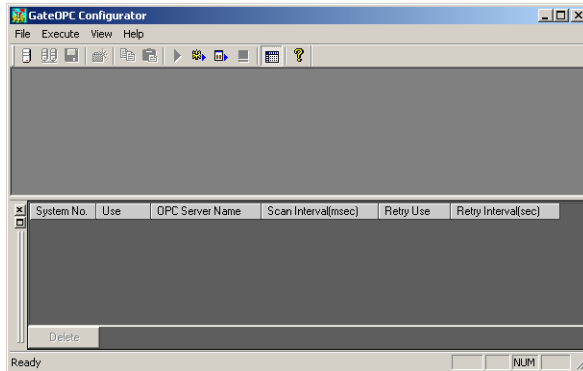

Note

- When you start GateOPC it is restored to the same status that was active during the previous session.
- If the program is closed while a process or service is running, the license will be considered to be "in use." If the message, "Invalid license number. Please reinstall." appears when restarting the program, it may indicate that the user is attempting to run a Gate program in excess of the number of available licenses.

Starting GateMX/MW in Acquisition Start Mode Procedure

1. From the Windows Start menu, choose **Programs > YOKOGAWA DAQWORX > GateOPC > GateOPC**, then right-click GateOPC and select Create Shortcut.
2. Right-click the shortcut icon and select Properties.
3. Choose the Shortcut tab, then add /START to the right of the path in the Target box and click OK.

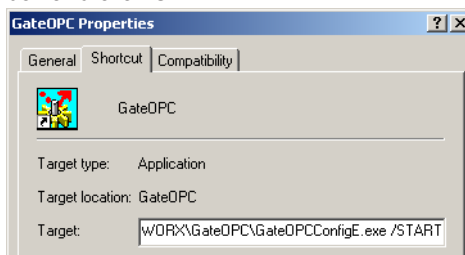

4. Choose the shortcut from the Windows Start menu. The connection status of the previous session is restored, and acquisition begins.

Exiting the Software Procedure

1. Choose **File > Exit from the menu bar**, or click the X button at the right end of the title bar.

GateOPC closes.

2.2 Entering Environment Settings

When you start GateOPC, the configurator opens allowing you to perform the following:

- Specify an OPC server
- Connect to an OPC server
- Edit an OPC server item
- Create/delete groups
- Add/delete group items
- Set item properties
- Test acquisition
- Run/stop the executable function (see section 2.3)
- Enter TCP/IP port numbers for monitor servers (see section 2.3)

Specifying an OPC Server

Procedure

1. Click the Addition of an OPC server button or choose **File > Addition of an OPC server from the menu bar.**



The Addition of an OPC server button

The Select OPC Server dialog box opens.

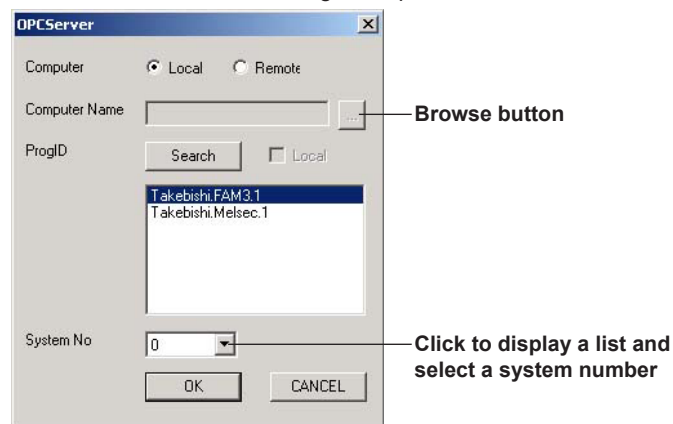

2. Enter settings for each item.

Computer: Select either Local or Remote.

Computer Name: Specify if you selected a remote computer. Enter the name of the computer when using DCOM. Click Browse to open the Browse Computers dialog box. Select a computer.

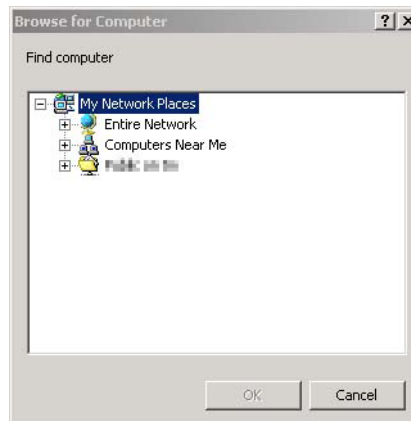

- ProgID: Click the Search button to display the ProgID list, then make a selection.
- If Local was selected above, the software searches for an OPC server on the local computer, then displays the results.
- If you selected Remote above, the software searches for a remote computer having the specified name, then searches that computer for an OPC server. Up to 80 characters can be entered for a computer name. However, if Local was selected, the ProgID of the local computer is displayed.
- System No: Select the system number to assign to the OPC server. You can display the OPC server list (see “Browsing OPC Server Items” in chapter 3) to see which OPC servers are assigned to which systems.
- Up to 16 OPC servers can be connected.

3. Click OK.

A list showing system numbers assigned to OPC servers is shown in the bottom of the GateOPCConfiguration screen.

Connecting/Disconnecting OPC Servers

Procedure

Connecting to Servers

1. Click the Connection button or choose **File > Connection from the menu bar**.



Connection button

A connection is opened with all active OPC servers.

Note

If the connection to an OPC server is cut, the causes may include the following:

- The software disconnected from the OPC server (see “Disconnecting from the Servers” below).
- The connection was cut due to the execution of a process or service.
- The connection was cut due to a problem on the OPC server.

Disconnecting from Servers

1. Choose **File > Disconnection from the menu bar**.

Connections with the active OPC servers are closed.

Note

The following restrictions apply if the connections to OPC servers are cut.

- OPC server items can not be displayed.
- Groups can not be added or deleted.
- Group names can not be changed.
- Groups items can not be added or deleted.

Displaying the OPC Server List, Changing Settings, and Deleting Servers

Procedure

Displaying the OPC Server List

1. Click the Show or hide OPC server list button or choose **View > OPC Server List** from the menu bar.

The OPC server list is displayed.

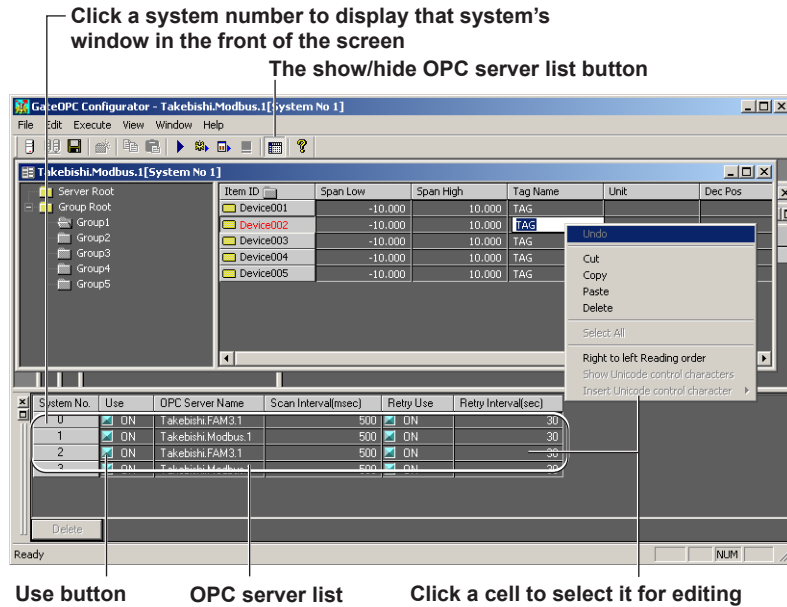

Use button OPC server list Click a cell to select it for editing

Changing OPC Server Settings

2. Click the button in the Use column to turn the item ON or OFF (Use/Don't use).
 ON (blue)
 OFF (gray)

Note

The Use button is active when running as a process or a service (see section 2.3). When running as a process or service, you can not connect to OPC servers that are turned OFF.

3. Click the Scan Interval box and change the value.
4. Click the button in the Use Retry column to turn communication retry ON or OFF. If turned ON, enter a Retry Interval.
 ON (blue)
 OFF (gray)
 Retry interval setting range: 30–3600 seconds.

Deleting OPC Servers

2. Select the system number of the OPC server you wish to delete.
3. Click the Delete button.

The selected OPC server is deleted from the list.

Displaying the OPC Server and Group Trees, and Editing Settings

- You can add new OPC servers (see page 2-2, "Specifying an OPC Server").
The OPC Server window is displayed in the GateOPCConfigurator screen, and the OPC Server Tree and Group Tree are displayed to the left of that window.

Note

The device, group, tag, items, and other information specified for the connected OPC servers is displayed.

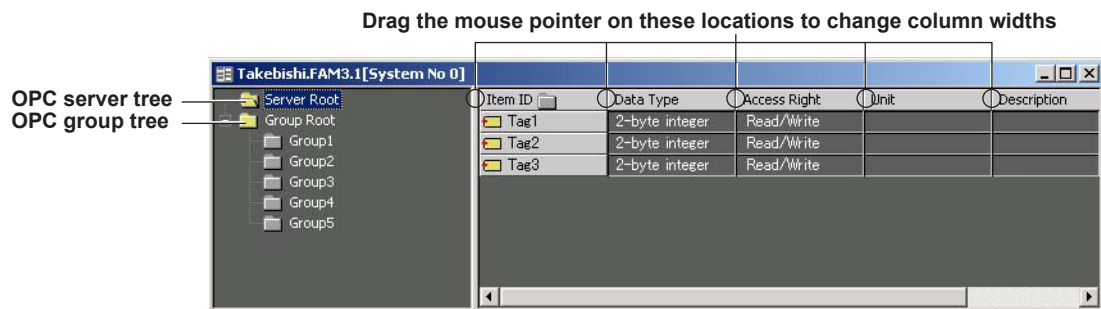

Displaying the OPC Server Tree

- Click the Server Root folder located to the left of the OPC server window inside the GateOPCConfigurator screen.

The server list is displayed.

Item ID	Data Type	Access Right	Unit	Description
TAG51	4-byte real	Read/Write	Percent	Boiler 5 Water
TAG52	4-byte real	Read/Write	Percent	Boiler 5 Water
TAG53	4-byte real	Read/Write	Percent	Boiler 5 Water

The following items are displayed.

- Item ID: The added item IDs (see "Adding and Deleting Items", 2 pages down) are displayed.
- Data Type: The type indicated by property ID1 (item canonical data type) (see "Adding Items to Groups" in section 3.2 for the symbol).
- Access Right: The access restrictions indicated by property ID5 (item access rights).
- | | |
|----------------------------|------------|
| OPC_READABLE | Read |
| OPC_WRITEABLE | Write |
| OPC_READABLE OPC_WRITEABLE | Read/Write |
- Unit: The string obtained from property ID100 (EU Unit).
If no property ID100 exists for the item, this cell is blank.
- Description: The string obtained from property ID101 (item description).
If no property ID101 exists for the item, this cell is blank.

Displaying OPC Groups

- Click the Group Root folder located to the left of the OPC server dialog box inside the GateOPCConfigurator screen.

The group list is displayed.



The following Information is displayed in the list.

Group Name: Specified names of each group

UpdateRate (ms): Display update interval (in units of msec)

Deadband (%): Deadband expressed as a percentage

Changing OPC Group Settings

- Click the cell of the item you wish to change then enter the new setting value.

Displaying and Changing Item Properties and Adding and Deleting Items

Displaying Item Properties

- Click the group name located in the Group Root folder to the left of the OPC server window.

The item properties are displayed in the OPC server window.

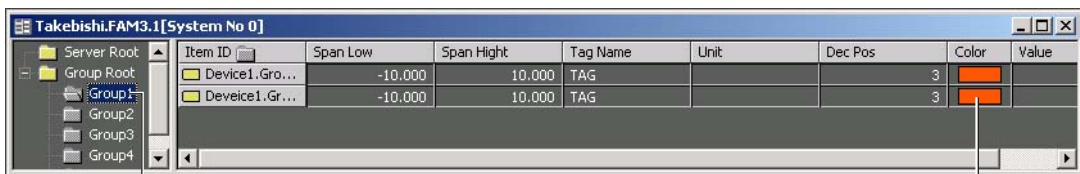

Click a group to display item properties

Click to display the color setting dialog box

The following information is displayed.

Item ID: The specified item ID is displayed.

Span Hight: The setting range is -1E16 to 1E16.
The number of digits before the decimal point is determined by the decimal place setting.

The initial value is that of the item's property ID102 (High EU).
If this property ID has not been defined on the OPC server, the value is set to 10.000.

Span Low: The setting range is -1E16 to 1E16.
The number of digits before the decimal point is determined by the decimal place setting.

The initial value is that of the item's property ID103 (Low EU).
If this property ID has not been defined on the OPC server, the value is set to -10.000.

Tag Name: Up to 16 alphanumeric characters can be input.

Unit: Up to 6 alphanumeric characters can be input. Enter only English alphanumeric characters.

The default value is obtained from property ID100 (EU Unit).

Dec Pos:	Select a decimal place from 0 to 4.
Color:	Select from the color selection dialog box.
Value:	Displays the values during test execution. The number of digits before the decimal point is determined by the decimal place setting.

Changing Item Properties

- Click a Span High, Span Low, Tag Name, or Unit cell, then change the setting.
- If you click a Dec Pos cell a list appears. Make a selection from the list.
- If you click a Color cell, the Color setting dialog box appears. Select a color in the dialog box.

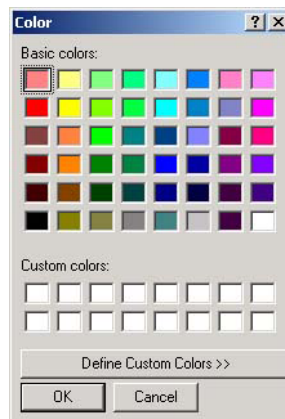

Adding and Deleting Items

Note

If the item does not exist on the OPC server, it cannot be added or deleted.

- **Adding and Deleting Items from the Menu Bar**

- Click the group name containing the item you wish to add or delete in the Group Root folder on the left side of the OPC server window.
- Choose **Edit > Add Item** or **Delete**.

- **Adding and Deleting Items from the Group Name List**

- Right-click the group name containing the item you wish to add or delete in the Group Root folder on the left side of the OPC server window.
The following menu is displayed.
- Choose Add Item or Delete.

Creating and Deleting Groups, and Changing Group Names

Procedure

Creating Groups

- **Using a Tool Button or Menu Command to Create Groups**

1. Click the Group creation button or choose **Edit > Group Creation** from the menu bar.



The Group creation dialog box opens.



2. Enter settings for each item.

Group Name: Up to 30 alphanumeric characters can be input. Up to 50 groups can be created. However, fewer than 50 groups may be allowed depending on the OPC server. The default value is GroupN (where N indicates the order in which the group was created). If the software fails to create the group, an error is displayed. groups can not have the same name.

UpdateRate: The setting range depends on the connected OPC server. See the specifications for the OPC server.

Deadband: You can enter the percent deadband, specifying when the groups will be updated. The setting range depends on the connected OPC server. See the specifications for the OPC server.

3. Click OK.

The group is created.

- **Using the Group List to Create Groups**

1. Right-click the Group Root folder name located in the left side of the OPC server dialog box.

The shortcut menu is displayed.

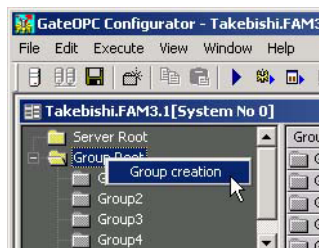

2. Click Create New Group.

Deleting Groups

- **Using the Menu Bar to Delete Groups**

1. Select the group you wish to delete.
2. Choose **Edit > Delete** from the menu bar.
The group is deleted.

- **Using the Group List to Delete Groups**

1. Right-click the group name located in the Group Root folder on the left side of the OPC server window.

The shortcut menu is displayed.

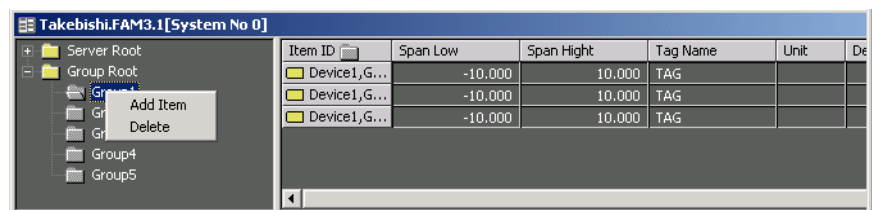

2. Select Delete.

Changing a Group Name

- **Using the Group List to Change a Group Name**

1. Click a cell in the group list containing a group name.



2. Change the name.

- **Using the Group List to Change Group Names**

1. Select a group name located in the Group Root folder to the left of the OPC server window.

2. Click the selected group name.

The name can now be changed.

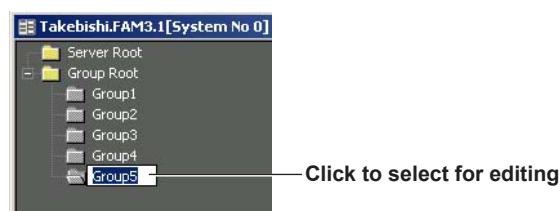

3. Change the group name.

Adding and Deleting Group Items

Note

These procedures are available only when connected with the OPC server.

Procedure

Adding Items

Up to 32 group items can be added.

- **Using the Menu Bar to Add Items**

1. Select the group to which you wish to add an item.
2. Choose **Edit > Add Item**.

The Add Item dialog box opens.

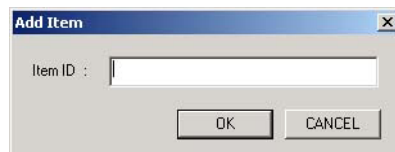

3. Enter an item ID.
4. Click OK.
The item is added.

- **Using the Group List to Add Items**

1. Right-click the group name located in the Group Root folder on the left side of the OPC server window.

The following menu is displayed.



2. Choose Add Item.
The Add Item window opens.
3. Follow steps 3 and 4 above under “Using the Menu Bar to Add Items.”

Deleting Items

- **Using the Menu to Delete Items**

1. Right-click the item you wish to delete.
The following menu is displayed.
2. Select Delete.

- **Using the Delete Key to Delete Items**

1. Click the item ID you wish to delete.
2. Press the Delete key on the PC.

Executing the Test Procedure

Executing the Test

1. Click the group name located in the Group Root folder to the left of the OPC server window.

The item properties are displayed in the right of the window.

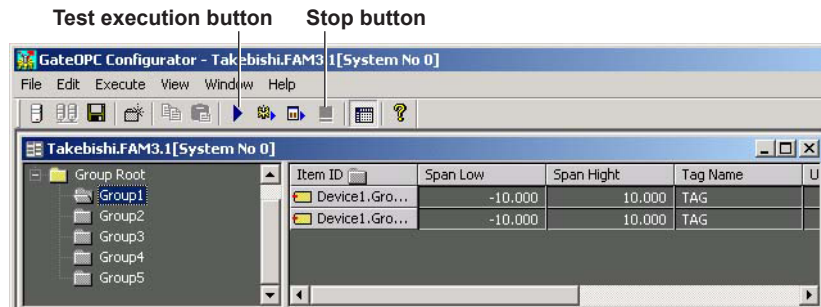

2. Select the item ID for which you wish to perform the test.
3. Click the Test Execution button on the tool bar or choose **Execute > Test** from the menu bar.

The test results are displayed in the value column of the item properties.

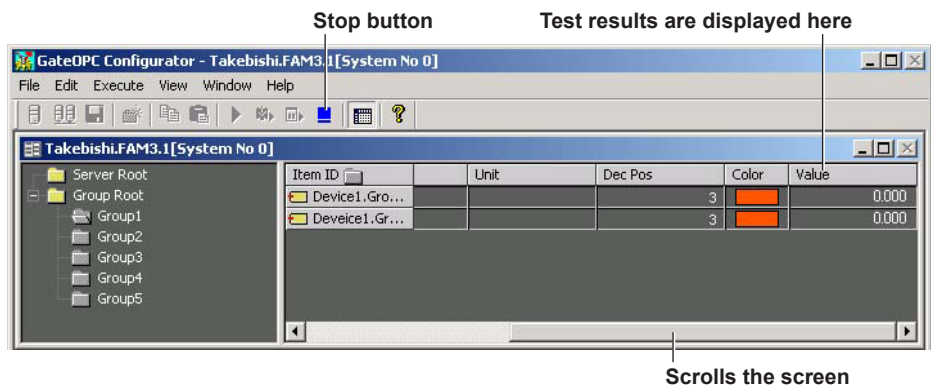

Stops the execution of the test

4. Click the Stop button on the tool bar or choose **Execute > Stop** from the menu bar.

2.3 Loading Data from the OPC Server and Transferring It to DAQLOGGER or Remote Monitor

By running the executable function, you can connect to and acquire data from the OPC server, then transfer that data to DAQLOGGER or Remote Monitor via Ethernet. GateOPC's executable function acts as the client of a DAQLOGGER or Remote Monitor that is running as the monitor server.

Procedure

Connecting to OPC Servers

1. Turn ON the OPC servers you wish to connect to in the Use column of the OPC server list.

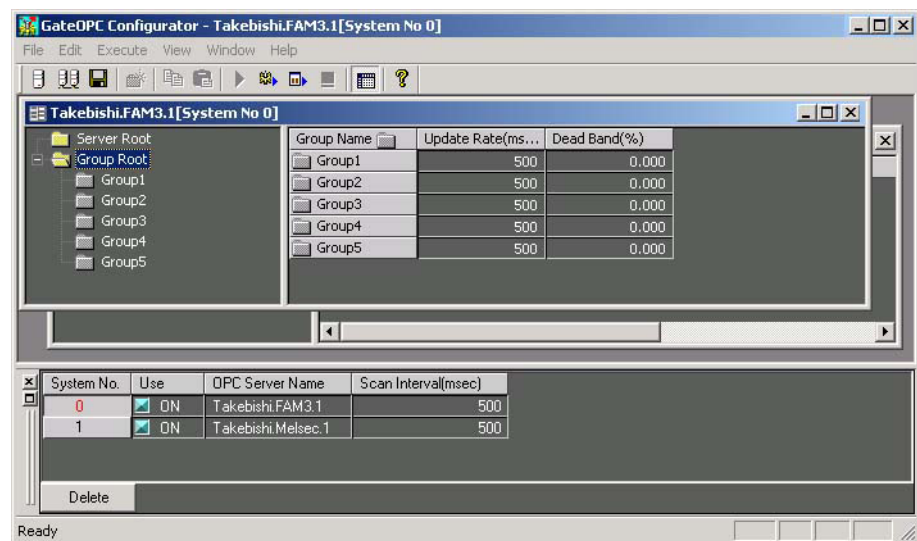

2. Connect to the OPC servers (see page 2-3, "Connecting/Disconnecting OPC Servers").

Entering TCP/IP Port Numbers for Monitor Servers

3. Choose **File > Port number** from the menu bar.
The PortSetting dialog box opens.

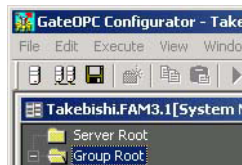

4. Enter the port number of the DAQLOGGER or Remote Monitor to which you wish to connect.

Note

- See the DAQLOGGER and Remote Monitor user's manuals to obtain the correct port numbers.
- Up to 16 GateOPCs can be connected simultaneously to DAQLOGGER or Remote Monitor.
- DAQLOGGER's recorder model determination function identifies the system number only.

Running as a Service or as a Process

5. Click the Service execution or Process execution button on the tool bar, or choose **Execute > Process or Service** from the menu bar.

A dialog box appears asking you whether or not to save before execution.

6. Click OK.

Data is loaded at the specified scan interval. The data is displayed in the value column.

Note

Execution occurs on OPC servers whose Use buttons are turned ON (blue) in the OPC server list.

Service execution button

Process execution button

Stop button

OPC server list

Communication retry is performed on all systems whose buttons are turned ON

All systems whose Use buttons are turned ON (blue) are run as a service or process

The GateOPC Information Software dialog box appears, and “Service” or “Process” is displayed under Practice Status.

Process or Service is displayed for the status

- Process
- Service
- Stop

Stopping a Service or Process

7. Click the Stop button on the tool bar or choose **Execute > Stop** from the menu bar.

“Stop” appears as the practice status in the Status Display dialog box.

Note

- Service execution can only be specified by users with Administrator privileges.
- Services cannot be executed when using Windows Vista.

2.4 Viewing the Status of the Executable Function

Displaying the Connection Status

Procedure

1. Choose **View > State Display**.

The GateOPC Information Software dialog box opens, allowing you to see the method under which the executable function may be running (as a process or as a service), whether or not it is running, and with which PCs communications are open.

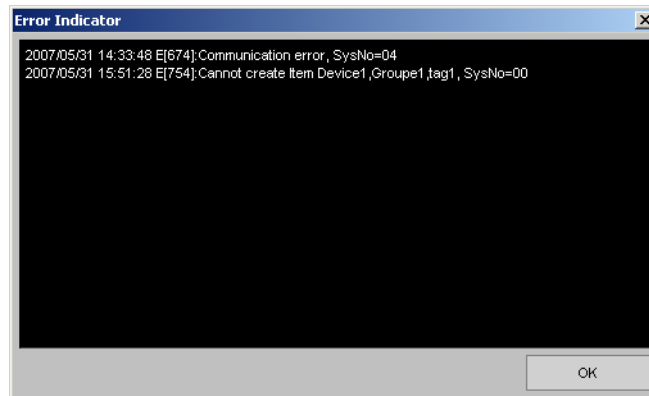
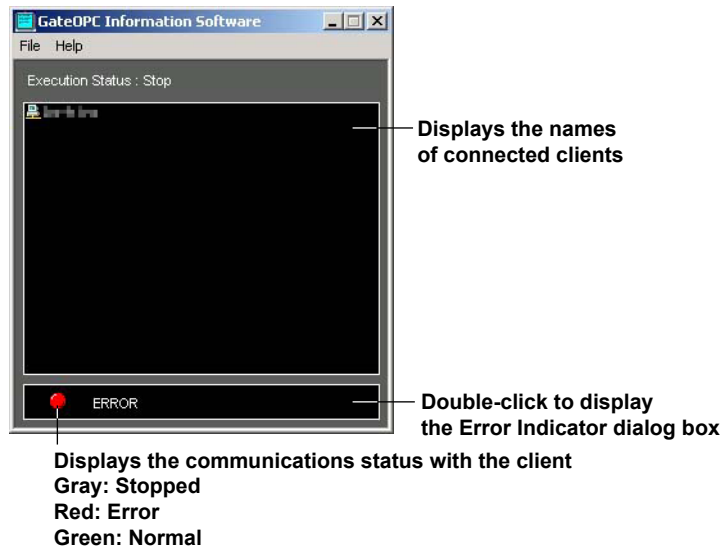

See section 3.3 for error messages.

Note

- If a warning message is displayed (code Wxxxx), the lamp that displays the connection status by color does not blink red.
- When an error occurs and the lamp blinks red, the Error Indicator dialog box appears. If you close the dialog box, the lamp turns green.

2.5 Viewing Version Information

Procedure

1. Click the About button or choose **Help > About** from the menu bar.



About button

The Version dialog box opens.

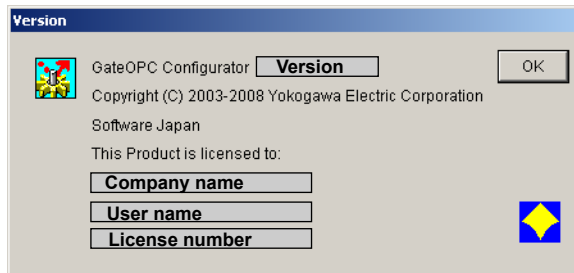

3.1 Overview

GateOPC performs COM or DCOM communications with OPC servers and acquires data at regular intervals. Through the monitor server function, the acquired data is transferred to DAQLOGGER or Remote Monitor via TCP/IP.

The following is a list of the features of each software function.

Environment Setting Functions

Environment setting functions are used to enter all environment settings required to run the executable function, to run/stop the executable function, and to run the status display function.

- **Specification of OPC Servers**
Specification of the remote PC name
Selection/setting of the ProgID¹
- **Connection to OPC Servers**
Up to 16 OPC servers can be connected
- **Browsing OPC server items²**
Display of item tree/list
Display of item properties
- **Creation/Deletion of Groups**
Up to 50 groups can be created³
Entering of group names
Setting of acquisition interval for each group⁴
Setting of the percent deadband for each group⁴
- **Adding/Deleting of Group Items**
Up to 32 items can be added to each group⁵
- **Setting of Item Properties**
Setting of upper/lower span
Entering of tag names (up to 16 characters)
Entering of units (up to 6 characters)
Setting of the decimal places (0 to 4)
Setting of colors
- **Tests Execution (Data Acquisition)**
- **Running/Stopping of the Executable Function**
Running of the executable function as a service
(Services cannot be executed when using Windows Vista.)
Running of the executable function as a process
Stopping the executable function
- **Setting of the TCP/IP Port Number for the Monitor Server**
- **Executable Function Status Display**
 1. The identifier for the OPC server (COM/DCOM server).
 2. Possible if the IOPCBrowseServerAddressSpace interface (optional) is installed on the OPC server.
 3. The number of allowable groups may be less than 50 depending on the server.
 4. The valid range depends on restrictions on the OPC server.
 5. The number of items that can be added to groups may be less than 32 depending on the server.

Executable Function

Features of the executable function are as follows:

- Running as a process and as a service is possible.
- Data is acquired from OPC servers at regular intervals.
- Runs as a monitor server if DAQLOGGER or Remote Monitor is the client.

Status Display Function

Features of the Status Display function are as follows:

- Executable Function Status Display

Practice status display (stopped, running as a service, running as a process).

The client connection status is displayed if DAQLOGGER or Remote Monitor is the client.

3.2 Detailed Description of Functions

OPC Server

GateOPC utilizes the OPC (OLE for process control) DA (data access) revision 2.0 server or later and COM/DCOM technology on the local machine or remote machine to form a connection and acquire data.

Interfaces Used

The interfaces for the OPC server are defined as shown in the figures below.
OPC Server Object

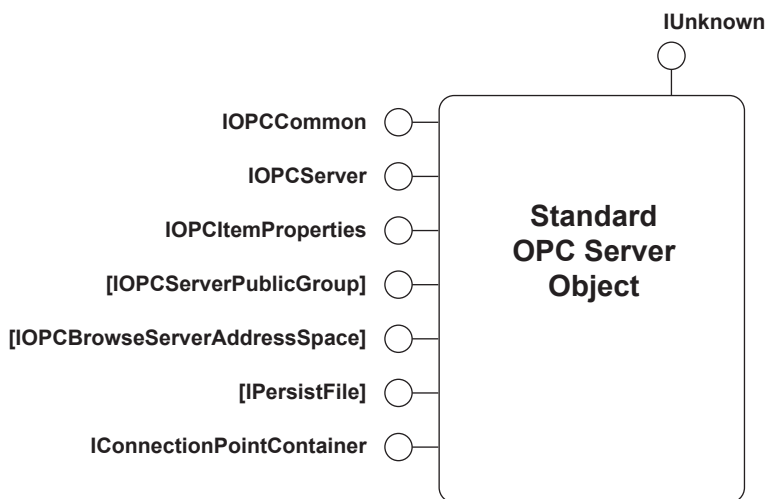

OPC Group Object

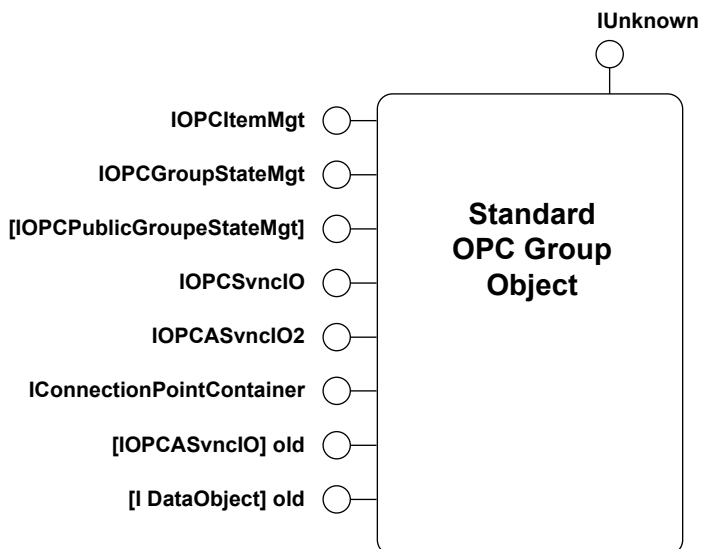

3.2 Detailed Description of Functions

The interfaces used by GateOPC are as follows:

- OPC Server Object
 - IOPCCommon
 - IOPCServer
 - IOPCItemProperties
 - IConnectionPointContainer
 - IOPCBrowseServerAddressSpace
- OPC Group Object
 - IOPCItemMgt
 - IOPCGroupStateMgt
 - IOPCSyncIO

Note

According to OPC DA version 2 conventions IOPCBrowseServerAddressSpace is optional, so GateOPC can run even if the OPC server does not have this interface. However, the OPC server item browse function is not available without this interface.

Name of Remote PC

When connecting to the OPC server on a remote PC, you must specify the PC name. Up to 80 characters can be entered for a PC name. In this case, the local PC must be able to access the remote PC.

The conditions for connecting with an OPC server on a remote PC are as follows: For details, see the user's manual for the OPC server.

- That the client can use DCOM on the server side computer.
- That the server grants remote access
- That OPCENUM.EXE is running on the server side computer

Selecting/Setting the ProgID

An OPC server is a type of COM server, so a ProgID is used to identify individual OPC servers.

GateOPC lists the ProgID of the OPC revision 2 server or later installed on the local PC or Remote PC from the registry categories. The user must select one of the ProgIDs from the list to specify an OPC server. Furthermore, to search the ProgIDs on the remote PC, openum.exe must be running on the remote PC. If unable to search for ProgIDs on the remote PC, see the OPC server's user's manual.

Simultaneous Connections of Up to 16 OPC Servers

With GateOPC, you can connect with up to 16 OPC servers and acquire data. You can also acquire data even when connecting to a combination of OPC servers residing on both remote and local PCs.

GateOPC assigns a system number to each OPC server to be connected. When connecting to GateOPC from DAQLOGGER or Remote Monitor and then acquiring data, this number is used to identify each OPC server.

Interval at Which Data Is Acquired from the OPC Servers

You can specify the interval at which data GateOPC acquires data from the OPC servers. The setting range is 0.5–3600 seconds. When connecting to multiple OPC servers, you can specify different acquisition intervals for each.

Depending on the server performance and quality of connection, the data acquisition interval may be insufficient, causing a data "Lack." If this occurs, lengthen the acquisition interval as needed.

Browsing OPC Server Items

This function not available if the IOPCBrowseServerAddressSpace interface is not installed on the OPC server.

You can search through all items on the OPC servers and display them in a format similar to the Windows explorer. You can display the layered structure of branch items, and all leaf items on each layer. The data type, access rights (read/write), units, and details are displayed for each leaf item.

Note

Units and details are optional properties, so they are not displayed if not installed on the OPC servers.

Creating Groups/Group Names

Up to 50 groups can be created on GateOPC. These groups support OPC server group objects. Therefore, fewer than 50 groups may be allowed depending on the OPC server configuration.

You can assign a name to each group. GateOPC limits the number of characters in a name to 30 characters. However, fewer than 30 characters may be allowed depending on the OPC server.

Note

- Per OPC DA conventions, each group name must be unique. No two groups may have the same name.
 - While the groups created here correspond to the OPC server settings as well as the group settings when GateOPC is connected from Remote Monitor. These group settings are not reflected on DAQLOGGER.
-

Group Data Update Interval

You can specify the data update interval for each group. The setting range depends on the OPC servers. The interval is expressed in milliseconds.

Note

These settings correspond to the OPC server settings. See the OPC DA specifications for details.

Group Percent Deadband

You can enter the percent deadband, specifying when the groups will be updated. The setting range depends on the OPC servers. The deadband is expressed as a percentage.

Note

These settings correspond to the OPC server settings. See the OPC DA specifications for details.

3.2 Detailed Description of Functions

Adding Items to Groups

You can add an item to a group. GateOPC limits the number of characters to 32. However, fewer than 32 may be allowed depending on the OPC server.

Note

These settings correspond to the OPC server settings and define GateOPC acquisition items.

An item may not be able to be added depending on its type. Data for each OPC DA item are of the VARIANT type, but whether or not addition of items to that type and group is allowed is as follows:

Data Type	Description	Group Add Allowed/Not Allowed ([YES]: Allowed, [NO]: Not Allowed)
VT_I2	Single precision integer	YES
VT_I4	Double precision integer	YES (or SHORT and LONG?)
VT_UI2	Single precision integer, no symbols	YES
VT_UI4	Double precision integer, no symbols	YES
VT_INT	Integer	YES
VT_UINT	Integer, no symbols	YES
VT_R4	Single precision floating point number	YES
VT_R8	Double precision floating point number	YES
VT_DATE	Day and time from 1899/12/30	NO
VT_BSTR	Character string	NO
VT_BOOL	0:FALSE -1:TRUE	YES
Other		NO

Setting Item Properties

You can specify the upper and lower limit of span, tag name (up to 16 characters), unit (up to 6 characters), decimal place (0 to 4), and color for each item registered to groups.

Note

These settings do not involve the OPC server; they are used when sending data from GateOPC to DAQLOGGER or Remote Monitor.

Colors are ignored by DAQLOGGER and Remote Monitor. Also, you can download tag names using tag setting software.

A decimal place is defined as a significant digit behind the decimal point. The following is an example of decimal place and data.

Actual data	Decimal places: 0	Decimal places: 1	Decimal places: 2	Decimal places: 3	Decimal places: 4
0.12345	0	0.1	0.12	0.123	0.1234

Acquiring Data at Fixed Intervals

The OPC server loads data from devices connected to the OPC server, stores it in the data buffer (cache), and updates it at the interval set in the procedure on page 3-5 and 2-7, "Data Update Interval for Groups." (Actually, the data is updated if the value set in the procedure under "Percent Deadband for Groups" (page 3-5) changes to a larger value. If the deadband is 0%, updating occurs each time.)

GateOPC loads the value stored in the internal buffer (cache) on the OPC server in synch with the update interval specified in "Interval at Which Data is Acquired from the OPC Server" (page 3-5 and 2-7).

The OPC server data loading operation and the GateOPC data loading operation when the deadband is 0% is shown in the figure below.

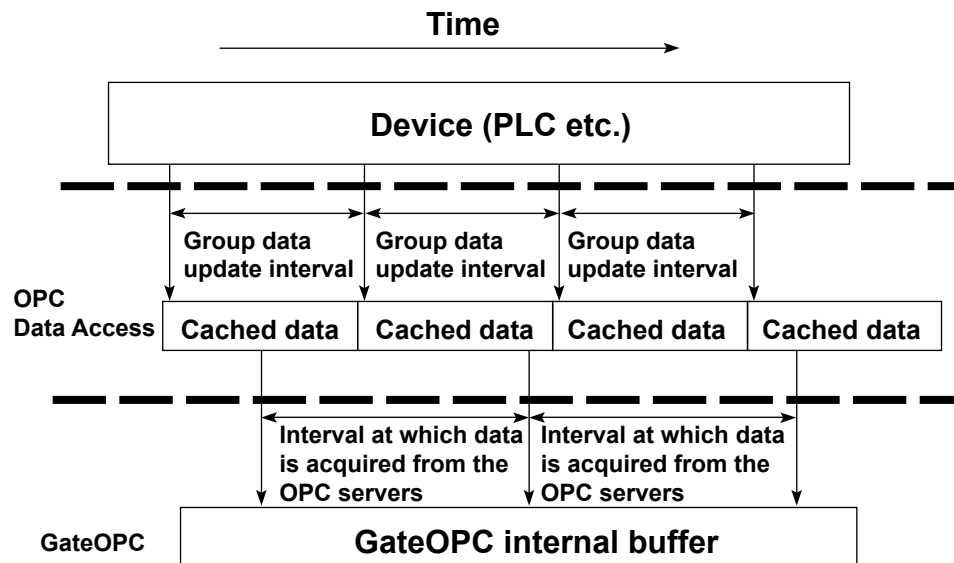

Time of GateOPC internal data

The time of GateOPC internal data (timestamp), is the time on the PC on which GateOPC is running at the time point at which GateOPC read data at synchronized IO (IOPCSyncIO).

If data was monitored by Remote Monitor, GateOPC's data time is used.

If data was acquired from GateOPC by DAQLOGGER, it is the time at which data was loaded by DAQLOGGER.

Test Acquisition

Using the configurator, you can connect to an OPC server and perform a test acquisition using the synch IO (IOPCSyncIO) after registering new items to groups.

Communication Retry

If the OPC server is shut down for reasons such as the PC power supply becoming disconnected, or being closed by the user, GateOPC retries communication with all OPC servers for which Use Retry is turned ON in the GateOPCConfigurator dialog box. The retry time is from 30 to 3600 seconds. At the point that communication is restored, the OPC server is created, the necessary information is retrieved from OPC, and data is acquired.

Scan Mode

When connecting with DAQLOGGER to acquire OPC data, if the number of channels in the GateOPC Configurator exceeds 1600, 1600 channels of data is sent to DAQLOGGER, starting with the first channel of the instrument of the smallest system number. Also, if an error occurs on an OPC during the first communication and communication is restored by executing a communication retry, connection is possible with that OPC in 1 scan mode without any channels being cut out.

Monitor Server Function

GateOPC takes data read in from devices and transfers the data to DAQLOGGER or Remote Monitor.

The maximum number of DAQLOGGERS or Remote Monitors that can be connected at once is 16.

Executable Function Status Display

The status display function allows you to display the following status items for the executable function.

- The executable function's practice status (running as a service, running as a process)
- The name of PCs running DAQLOGGERS and Remote Monitors connected to a monitor server.

3.3 Message and Corrective Actions

Error

No.	Message	Corrective Actions
E211	Cannot write to file.	Check if the disk capacity is sufficient or if the file systems is normal.
E212	Cannot read file.	Check if the file exists and is supported by the software or if the file system is normal.
E213	Cannot open file.	Check if the file exists and is supported by the software or if the file system is normal
E401	Communication error.	Check if the recorder connected for communication is powered on and if the cable is properly connected. Also check the following items according the communication type. <ul style="list-style-type: none"> • For Ethernet Check if address settings are correct; the TCP/IP protocol is installed in Windows; the Ethernet card is properly installed. • For RS-232 and RS-422 Check if the baud rate settings match; the port (COM1 to COM9) settings match, the address settings are correct (RS-422); the serial port of the PC is active and the appropriate cable is being used.
E402	Communication timeout.	–
E403	Cannot open a communication port.	Same as E401.
E501	Invalid license number. Please reinstall the software.	Install the software again.
E1010	Execution of a process failed.	Check whether an executable function exists, or whether its files are damaged. If this error appears frequently, reinstall the software.
E1011	Execution of a service failed.	Check whether an executable function exists, or whether its files are damaged. If this error appears frequently, reinstall the software.
E1301	Cannot connect OPC server.	Check whether the OPC server is available.
E1302	Execution of status display function failed.	Check whether an executable function exists, or whether its files are damaged. If this error appears frequently, reinstall the software.
E1303	Failed to create group.	An error was returned from the OPC server when creating a group. Check the status of the OPC server.
E1304	Failed to create item.	An error was returned from the OPC server when creating an item. Check the status of the OPC server.

Warning

No.	Message	Corrective Actions
E1401	Computer not found.	Check whether the specified computer exists on the network, or whether the network is functioning normally.

Message

No.	Message
M1201	Model determination was successful.
M1210	Setting changes saved before execution.
M1501	Delete server?
M1502	Delete selected item?
M1503	Delete selected group?

3.3 Message and Corrective Actions

Executable Function Messages

No.	Message	Corrective Actions
W[631]	Data Lack	Reduce the number of acquired data points or connected instruments, or lengthen the scan interval.
E[637]	Cannot open communication	Same as E401.
E[674]	Communication error	Same as E401.
E[675]	Communication time out	Same as E401.
E[750]	Cannot create OPC server	Same as E1301.
E[751]	Cannot create Interface OPC	Check whether the OPC server is functioning correctly.
E[752]	Cannot create Interface Shutdown	Check whether the OPC server is functioning correctly.
E[753]	Cannot create Group	Same as E1301.
E[754]	Cannot create Item	Same as E1304.
E[755]	Shutdown OPC Server	The OPC server was shut down during communication. Check the status of the OPC server.
I[606]	Recovery Communication	Connection recovered.

Index

A

- acquiring data at fixed intervals 3-7
- adding and deleting items 2-7
- adding items 2-10
- adding items to groups 3-6

B

- browsing OPC server items 3-5

C

- changing item properties 2-7
- changing settings 2-4
- communication retry 3-7
- computer name 2-3
- connecting OPC servers 2-3
- connecting to OPC servers 2-12
- creating groups 3-5

D

- data acquisition interval 3-4
- deleting items 2-10
- deleting servers 2-4
- disconnecting OPC servers 2-3
- displaying and changing item properties 2-6
- displaying the connection status 2-14
- displaying the OPC server and group trees 2-5
- displaying the OPC server list 2-4

E

- editing settings 2-5
- environment setting functions 1-3, 3-1
- environment settings 2-2
- executable function 1-3, 3-2
- executing the test 2-11
- exiting the software 2-1

F

- functions 1-1

G

- group data update interval 3-5
- group names 3-5
- group percent deadband 3-5

H

- hardware requirements 1-2

I

- interfaces used 3-3

M

- message 3-9
- monitor server function 3-8

N

- name of remote pc 3-4

O

- opc server 3-3
- overview 1-2, 3-1

P

- Port number 2-12

R

- required operating systems 1-2
- running as a process 2-13
- running as a service 2-13
- running the software 2-1

S

- scan mode 3-8
- selecting/setting the progID 3-4
- setting item properties 3-6
- simultaneous connections 3-4
- software configuration 1-3
- software license ii
- specifying an OPC server 2-2
- status display 3-8
- status display function 1-3, 3-2
- stopping a service or process 2-13
- system 1-2
- system configuration 1-3

T

- test acquisition 3-7
- time of GateOPC internal data 3-7

V

- version information 2-15